



Since 1954

Snowmobile Trailers



***Adventures
In The Making!***

*With a Wells Fargo Behind... You Never Look Back!*TM

2-SLEDS

The Shape of Performance

The innovative 2-Sled V-Front funWagon® combines performance, durability, and accessibility into a streamlined body profile. The stylish front tapered nose with spring-assisted ramp door provides the most convenient drive-off unloading possible. No need to turn or “jackknife” your tow vehicle to lower the 60” wide ramp door. Fewer hassles and less time unloading mean more time in the great outdoors. The 5 ft. long V-Front nose section frees up more interior storage space; extra room for equipment, tools, parts, and supplies.

The rear ramp door with spring assist allows you to load up and head home in record time. The hidden rear beavertail lowers platform height and reduces the loading angle without sacrificing ground clearance.

Solid engineering delivers solid performance. Even though a snowmobile trailer may be considered a recreational trailer by some, the funWagon® has the same rugged heritage as our commercial grade trailers.

Choose from four (4) different 2-Sled V-Front funWagon® models with body lengths ranging from 15 ft. to 21 ft.



Anodized Aluminum Nose & ATP Stone Guard



12 Volt Dome Lights



E-Coated Wheels & Mud Flaps



V-Front funWagon® Includes:

- 5 ft. Long V-Front Section
- 60” Wide Front Ramp Door with Spring Assist
- 92” Wide Rear Ramp Door with Spring Assist
- Rear Cornerpost Jacks
- Reinforced “No Show” Beavertail (*rear only*)
- Anodized Aluminum on Front Nose Section
- ATP Stone Guard
- Ski Guide on Front Ramp
- LED Exterior Lighting includes Wells Cargo Exclusive Safety Package
- 12V Dome Lights
- Extruded Anodized Aluminum Roof Cove & Bottom Trim
- Torflex® Rubber Torsion Suspension
- Electric Brakes featuring Dexter Nev-R-Adjust
- 15” Radial Tires
- 5-Bolt, E-Coated Silver Spoke Wheels
- Mud Flaps
- Corrosion Preventative Compound Undercoating
- Pressure Treated Plywood Floor with 20 Year Limited Warranty
- .030 Prefinished Aluminum Exterior Skin (*11 colors*)
- Jack Ram Hoist with Sand Pad
- Safety Chains Meet D.O.T. Requirements
- Breakaway System with Wet Cell Battery

Model FW192V

(Features optional equipment available at additional charge.)



Model FW192V

(Features optional equipment available at additional charge.)



V-Front funWagon® (2 Sleds)

4-SLEDS

More Room. More Friends. More Fun!

Adventure loves company and nothing makes it easier to bring along your entire crew for a day of fresh powder pounding than the 4-Sled V-Front funWagon®. From hitch to tail light, it's loaded with all the extras: extra room, extra storage and extra toughness — after all, it is a Wells Cargo.

So, while you're traveling in your warm tow vehicle looking for the next stop on your winter wonderland expedition, your sleds are protected from the harsh elements and safely cushioned by the smooth ride only Torflex® Rubber Torsion Axles can deliver. When you finally arrive at your destination, just drop the spring-assisted front ramp door and head out to the trails or the deep powder. The adventure begins when the pavement ends.

Choose from four (4) different 4-Sled V-Front funWagon® models with body lengths ranging from 23 ft. to 29 ft.



60" W Front Ramp Door w/ Spring Assist (*optional Traction Blocks*)



Aluminum Ski Guide



Aluminum Anti-Rack Cam Bar

V-Front funWagon® Includes:

- 5 ft. Long V-Front Section
- 60" Wide Front Ramp Door with Spring Assist
- 92" Wide Rear Ramp Door with Spring Assist
- Rear Cornerpost Jacks
- Reinforced "No Show" Beavertail (*rear only*)
- Anodized Aluminum on Front Nose Section
- ATP Stone Guard
- Ski Guide on Front Ramp
- LED Exterior Lighting includes Wells Cargo Exclusive Safety Package
- 12V Dome Lights
- Extruded Anodized Aluminum Roof Cove & Bottom Trim
- Torflex® Rubber Torsion Suspension
- Electric Brakes featuring Dexter Nev-R-Adjust
- 15" Radial Tires
- 5-Bolt, E-Coated Silver Spoke Wheels
- Mud Flaps
- Corrosion Preventative Compound Undercoating
- Pressure Treated Plywood Floor with 20 Year Limited Warranty
- .030 Prefinished Aluminum Exterior Skin (*11 colors*)
- Jack Ram Hoist with Sand Pad
- Safety Chains Meet D.O.T. Requirements
- Breakaway System with Wet Cell Battery

Model FW292V

(Features optional equipment available at additional charge.)



Model FW292V

(Features optional equipment available at additional charge.)



Great for ATV's, too!

V-Front funWagon® (4 Sleds)

funWAGONS

2-SLEDS

Streamline Your Travels

The sleek In-Line funWagon® is designed to accommodate today's longer and wider snowmobiles. Snowmobiles (2) are arranged in a row – front to end. Just like the other models in the funWagon® series, the In-Line features an aerodynamic V-Front nose, front ramp door and rear ramp door (both with spring assist). The real differences lie in the In-line's width (6' wide) and axle/wheel configuration. The radial tires and silver spoke wheels are positioned completely outside the body providing a lower profile, superior handling, obstruction free interior (no interior wheel boxes), and a load-friendly 22" platform height.

The In-Line funWagon® won't stay in your garage during the off-season either. Truly multi-use, it's built tough to follow you from season to season and from sport to sport. With the right cargo control accessories, you can easily haul ATV's, motorcycles, rails, karts; whatever your thrill ride of choice.

Your fun doesn't have to end when the snow melts!

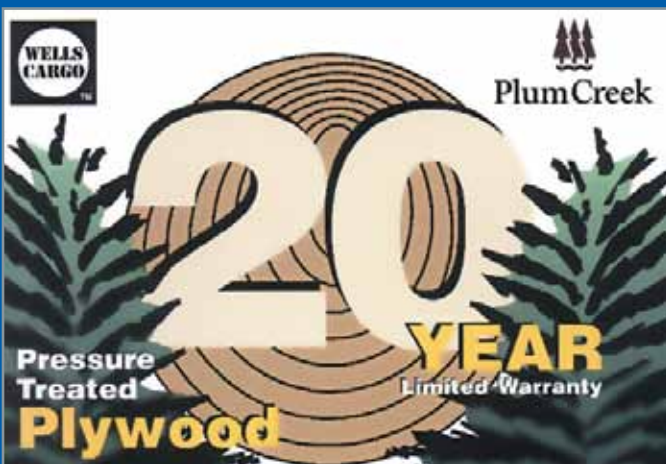

Pressure Treated Plywood Floor with 20 Year Limited Warranty

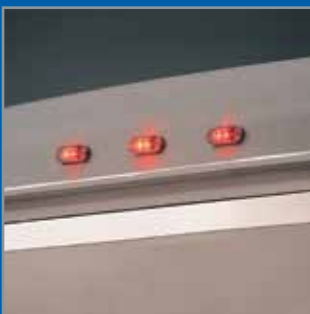

Wells Cargo LED Safety Package



LED Exterior Lighting

In-Line funWagon® Includes:

- 5 ft. Long V-Front Section
- 55" Wide Front Ramp Door with Spring Assist
- 64" Wide Rear Ramp Door with Spring Assist
- Rear Cornerpost Jacks
- Anodized Aluminum on Front Nose Section
- ATP Stone Guard
- Ski Guide on Front Ramp
- LED Exterior Lighting includes Wells Cargo Exclusive Safety Package
- 12V Dome Lights
- Extruded Anodized Aluminum Roof Cove & Bottom Trim
- Torflex® Rubber Torsion Suspension
- Electric Brakes featuring Dexter Nev-R-Adjust
- 15" Radial Tires
- 5-Bolt, E-Coated Silver Spoke Wheels
- Smooth Aluminum Fenders
- Corrosion Preventative Compound Undercoating
- Pressure Treated Plywood Floor with 20 Year Limited Warranty
- .030 Prefinished Aluminum Exterior Skin (11 colors)
- Jack Ram Hoist with Sand Pad
- Safety Chains Meet D.O.T. Requirements
- Breakaway System with Wet Cell Battery

Model FWS252V

(Features optional equipment available at additional charge.)



Model FW5252V

(Features optional equipment available at additional charge.)



In-Line funWagon® (2 Sleds)

FUNWAGON® SPECIFICATIONS

		# of Snowmobiles	Body: Width	Body: Length	Overall: Length	Overall: Width	Overall: Height	Interior: Length	Interior: Length <small>(Excluding V-Front)</small>	Interior: Width	Interior: Height	Platform Height	Axle: Quantity	Axle: Suspension	Radial Tire Size	Load Range	Hitch Ball Size
FW 2 Sled	FW151-VF	2	99¾"	15'0"	17'10"	99¾"	9'2"	14'8½"	9'9½"	97"	6'6"	27"	1	Torflex®	15"	D	2"
	FW172-VF	2	99¾"	17'0"	19'10"	99¾"	9'1"	16'8½"	11'9½"	97"	6'6"	26½"	2	Torflex®	15"	C	2½"
	FW192-VF	2	99¾"	19'0"	21'10"	99¾"	9'1"	18'8½"	13'9½"	97"	6'6"	26½"	2	Torflex®	15"	C	2½"
	FW212-VF	2	99¾"	21'0"	23'10"	99¾"	9'1"	20'8½"	15'9½"	97"	6'6"	26½"	2	Torflex®	15"	C	2½"
FW 4 Sled	FW232-VF	4	99¾"	23'0"	25'10"	99¾"	9'1"	22'8½"	17'9½"	97"	6'6"	26½"	2	Torflex®	15"	C	2½"
	FW252-VF	4	99¾"	25'0"	27'10"	99¾"	9'1"	24'8½"	19'9½"	97"	6'6"	26½"	2	Torflex®	15"	C	2½"
	FW272-VF	4	99¾"	27'0"	29'10"	99¾"	9'1"	26'8½"	21'9½"	97"	6'6"	26½"	2	Torflex®	15"	C	2½"
	FW292-VF	4	99¾"	29'0"	31'10"	99¾"	9'2"	28'8½"	23'9½"	97"	6'6"	27"	2	Torflex®	15"	D	2½"
FWS 2-Sled	FWS212-VF	2	72"	21'0"	23'2"	102"	8'8"	20'8½"	15'9½"	69"	6'6"	22"	2	Torflex®	15"	C	2½"
	FWS252-VF	2	72"	25'0"	27'2"	102"	8'8"	24'8½"	19'9½"	69"	6'6"	22"	2	Torflex®	15"	C	2½"

NEV-R-ADJUST™

FORWARD SELF-ADJUSTING ELECTRIC BRAKES

Dexter Axle Nev-R-Adjust Brakes Now Standard

Nev-R-Adjust self-adjusting brakes offer a convenient solution that saves time, reduces expense and improves safety compared to manual brake adjustments. Nev-R-Adjust brakes have been extensively tested and proven to reduce stopping distances up to 50% — every second counts in an emergency stopping situation.

CONSTRUCTION FEATURES

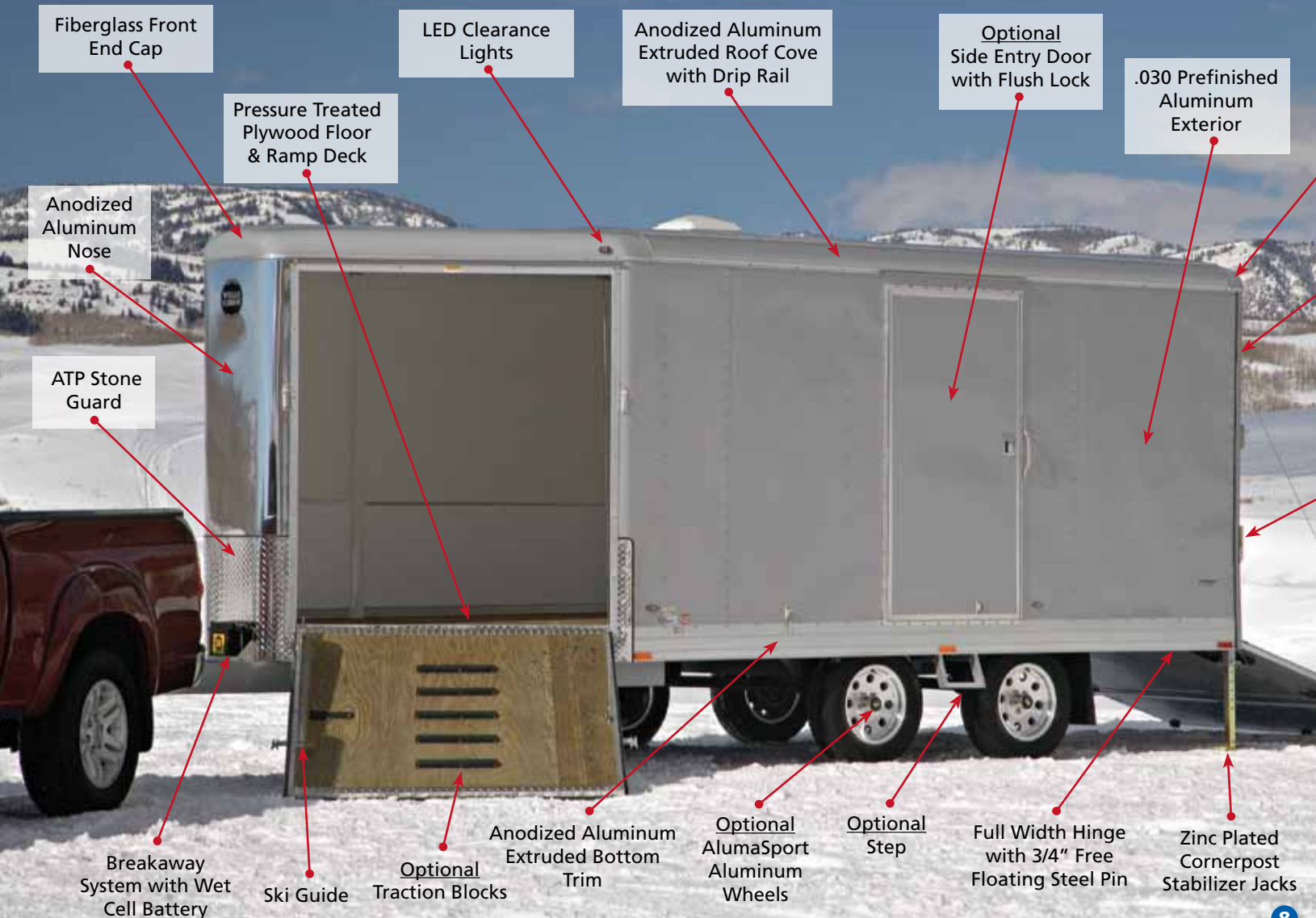

Hitch to Top of Ball	Hitch Weight	Curb Weight (lb.)	GVWR (lb.)	Average Payload (lb.)	Rear Door (W x H)	Front Door (W x H)	12V Dome Lights	500 lb. Tie-Downs (Shipped Loose)	12V Trailer End Connector
23"	10-15%	2125	5500	3375	92"x 66"	60"x 62"	1	4	7-Way
22"	10-15%	2375	7600	5225	92"x 66"	60"x 62"	2	4	7-Way
22"	10-15%	2625	7600	4975	92"x 66"	60"x 62"	2	4	7-Way
22"	10-15%	2750	7600	4850	92"x 66"	60"x 62"	2	4	7-Way
22"	10-15%	2875	7600	4725	92"x 66"	60"x 62"	2	6	7-Way
22"	10-15%	3125	7600	4475	92"x 66"	60"x 62"	2	6	7-Way
22"	10-15%	3375	7600	4225	92"x 66"	60"x 62"	2	6	7-Way
23"	10-15%	3770	10000	6230	92"x 66"	60"x 62"	2	6	7-Way
19½"	10-15%	3400	7600	4200	64"x 63"	55"x 63"	2	3	7-Way
19½"	10-15%	3700	7600	3900	64"x 63"	55"x 63"	2	3	7-Way

Specifications and features subject to change without notice.



Solid Support Down The Road

After you make the decision to buy a Wells Cargo, our commitment to you is not over. Our comprehensive 6-Year Warranty Program is more than just words. It's about how quickly and responsibly we respond to your needs. It's the peace-of-mind you get knowing your investment is protected by an established company with a solid reputation.

Fiberglass Rear End Cap

Radius Steel Cornerposts

LED Stop/Tail/Turn Lights

All Aluminum Anti-Rack Cam Lock

Rear Ramp Door with Spring Assist

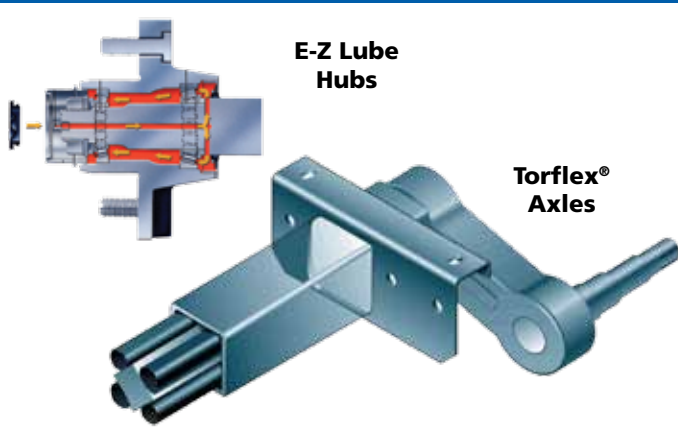

Torflex® Rubber Ride Axles with E-Z Lube Hubs
Equipped with Torflex® rubber torsion system with progressive torque action and independent wheel movement for maximum shock absorption and road stability. E-Z Lube hubs with outside grease fittings for bearing lubrication without disassembly. E-Coated Wheels and radial tires.



12 Volt Electrical System
All 12 volt wiring is completely weather protected with no direct exposure to the elements or road hazards. Starting at the sealed A-frame junction box, the molded, 4-wire cable is routed inside the tubular main rail. All brake wiring is run through a plastic conduit into a special welded channel on the axle.



Ramp Door & Cornerpost Jacks
Full width hinge with free floating 3/4" steel pin. Stronger than strap hinges. Won't bind. Welded perimeter frame with gussets at major stress points. Full length reinforcements prevent bowing. Spring assist cable(s) for safety. Rear Cornerpost stabilizer jacks with steel tube post are coated in Zinc Dichromate for rust resistance.



Breakaway System with Wet Cell Battery
Essential part of breakaway system. Applies trailer's full braking capacity for a minimum of 15 minutes meeting D.O.T. requirements. Low voltage indicator light. Up to 100 recharges.

OPT

Options, Upgrades & Customizing

Every Wells Cargo funWagon® is jam-packed with a laundry list of quality standard features. From a practical point of view, that's what you want.

However, the real thrill comes from taking that dream trailer concept in your head and turning it into a reality. Wells Cargo has the selection, the resources, and the experience to build your snowmobile trailer just the way you want it. Is flash your style? Choose from hundreds of striking exterior options. Or, maybe you're more of a "Do-It-Yourselfer" and prefer a garage on wheels. We can do that, too. Check out our generous assortment of interior upgrades that will really make you feel at home. It doesn't matter the size or the application, Wells Cargo is up to the challenge.



Bonded Aluminum Exterior

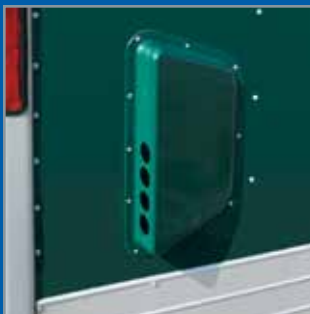

Flow-Thru Side Vents



Halogen Exterior Lights

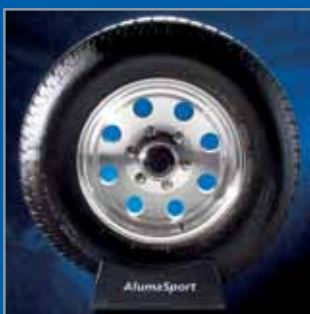

AlumaSport Aluminum Wheels





5



6



7



8



9



10



11

1. Swing-Out Spotlight
2. New Wide Mouth Front Ramp Door with 79" Opening
3. Halogen Backup Light
4. Overhead Cabinet with 34,000 BTU Furnace, Roof Vent & Dome Light
5. Overhead Cabinet
6. Side Entry Door
7. 12 Volt Power Jack Ram Hoist
8. 5000 lb. Floor Mounted Tie-Offs
9. Traction Blocks
10. Roof Vent Cover
11. Fuel Access Door

.030 Prefinished Aluminum Skin



White



Victory Red



Black



Pewter



Indigo Blue



Champagne



Brandywine

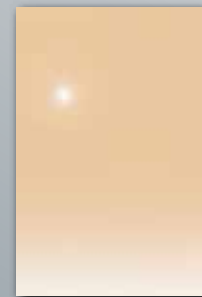

Beige



Charcoal Gray



Dove Gray



Dark Green

Skin colors shown are representative only. See your dealer for accurate samples.

EXTERIOR COLORS

Wells Cargo and Our Legacy of Engineering Leadership



Many people say that all enclosed trailers look pretty much alike. We consider that a compliment since it was Wells Cargo who pioneered the industry over 55 years ago. State-of-the-art takes on a whole new meaning when you compare the first trailer we built in 1954 with our product line today. Old "No. 1" looked pretty good back then, but we've come a long way since. Experience has made the difference and ours is unmatched. Our Research & Development facilities keep us the frontrunners of the industry. After thorough evaluation and comparison, we think you'll agree that Wells Cargo has earned our long standing reputation as the premium cargo trailer on the market and the best overall investment.

Rest assured that after you make the decision to buy a Wells Cargo, our commitment to you is not over. Our comprehensive 6-Year "Never Look Back" Warranty Program is more than just words. It's about how quickly and responsibly we respond to your needs. It's the peace-of-mind you get knowing your investment is protected by an established company with a solid reputation. If our work or materials are at fault, we'll make it right. Any one of our six manufacturing facilities or our national network of professional dealers stand ready to service your trailer should the unlikely need arise.



More Great Trailers

For **WORK**, durable Wells Cargo trailers are used every day by Contractors, Landscapers, Fire Departments, Utility Companies, Heavy and Light Industry; anywhere value of investment is critical.

For **FUN**, you'll see Wells Cargo trailers carrying race cars, collector cars, snowmobiles, motorcycles, ATV's, antiques, and recreational/sporting equipment; anywhere reliable service and carefree towing is a must. You'll see Wells Cargo trailers pulled by big trucks, little trucks, passenger cars, and motorhomes.

You'll find Wells Cargo trailers in almost any situation requiring dependable, economical transportation and storage.



AUTHORIZED WELLS CARGO DEALER



©Wells Cargo, Inc. 2007 LITHO USA Form FUNWAGON907R1009