



Since 1954

Gooseneck Trailers



***The Big Job,
High Cube Authority***

With a Wells Cargo Behind . . . You Never Look Back!™

Models



The Wells Cargo CompacVan® is the largest trailer we build with body lengths up to 48'. When teamed up with a one-ton truck, you've got a rugged combination to tackle the really big jobs. No stranger to hard work, the CompacVan® delivers substantial cubic capacity for high volume loads and GVWR's ranging from 14,700 to 22,500 lbs. Developed specifically for industrial and commercial applications, long lasting durability is engineered from the ground up. The real difference is in the details; reinforcing gussets at all major stress points, weather protected brake wiring, Nev-R-Adjust brakes and door hinges with grease zerks. You won't find a longer lasting trailer or one that requires less maintenance . . . period!



Tapered Nose* Provides Excellent Maneuverability and Maximum Turning Radius with Short Bed Trucks



Quality Features That Deliver the Goods!



LED Stop/Tail/Turn Lights: LED's are proven to be brighter, safer, more durable and consume 90% less power than incandescent lighting.



Tandem, 2-Speed Landing Gear: The dual gear ratio crank makes raising/lowering your trailer much easier especially with heavier payloads.



2⁵/₁₆ Adjustable Height Ball Hitch: Other hitch configurations available as optional equipment.



CompacVan® Gooseneck Model CVG3225W-T*

**Tapered Nose is a no-charge option.*



CompacVan® Gooseneck- Model CVG3625W



**CompacVan® Gooseneck- Model CVG3625
(with Optional Fixed King-Pin Hitch)**



CompacVan® Gooseneck - Model CVG4039

All models featured show optional equipment available at additional charge.

Features



Notched For Smoother Sidewalls

Body Frame & Roof Bows

One-piece roof bows are galvanized steel hat sections welded directly to top sidewall sills for rigid anchoring. Vertical wall posts are on 16" centers and notched (see inset) for a smooth, level surface to attach exterior skin. Eliminates bowed sides.

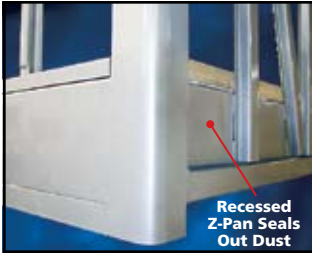

Recessed Z-Pan Seals Out Dust

Radius Corner Posts & Dust Barrier

Radius steel corner posts, front and rear, extend to the bottom of the frame providing the maximum welding surface possible for long-lasting durability. Recessed bottom sidewall rail (Z-Pan) seals out dust and other road elements.



Flush Floor Installation Will Not Snag Cargo

End Rail with Floor Guard

One-piece, formed steel rear end rail with recessed lip allows flush installation of decking material. Smooth transition protects floor edge from snagging on cargo during loading/unloading. Especially important in high-use applications. Attention to detail and superior "fit & finish" are Wells Cargo trademarks.

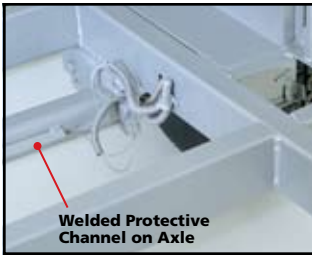

Welded Protective Channel on Axle

12 Volt Electrical System

All 12 volt wiring is completely weather protected with no direct exposure to the elements or road hazards. Starting at the sealed A-frame junction box, the molded, 4-wire cable is routed inside the tubular main rail. All brake wiring is run through a plastic conduit into a special welded channel on the axle.



Corrosion Preventive Measures

Every Wells Cargo chassis is undercoated with a laboratory tested, Corrosion Preventative Compound (CPC), to deter the accumulation of rust. Painted steel surfaces feature a state-of-the-art process including both a primer & urethane topcoat for a smooth, long lasting finish. Also, a special corrosion resistant tape is applied between the steel frame and exterior aluminum skin to prevent electrolysis.

More Standard Features . . .

- Dual, 2-Speed Landing Gear
- Tubular Steel Main Rails
- Full Height C-Channel Crossmembers
- Heavy Gauge Full Width End Rails
- LED Clearance Lights
- 3/8" Exterior Grade Plywood Sidewall Lining
- 3/4" Exterior Grade Plywood Flooring
- Zinc Plated Steel Strap Hinges with Grease Zerk
- Extruded Aluminum Trim with Anodized Finished
- Extra Strong Safety Chains to D.O.T. Standards
- Junction Box with SAE Truck/Trailer Color Coded Wiring
- Wet Cell Battery with Low Voltage Indicator

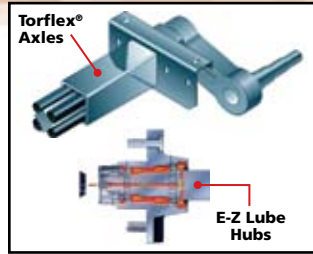

Torflex® Axles

E-Z Lube Hubs

Torflex® Rubber Ride Axles with E-Z Lube Hubs

Equipped with Torflex® rubber torsion suspension system with progressive torque action and independent wheel movement for maximum shock absorption and road stability. E-Z Lube hubs with outside grease fittings for bearing lubrication without disassembly.



Wheels/Tires/Fenderettes

Brand name radial tires specifically engineered to match trailer capacity. Silver spoke wheels painted with an Electrodeposition paint process (E-Coating) for maximum corrosion resistance. Durable formed aluminum Fenderettes are milled finished for a smooth, attractive, rust resistant appearance. Easy to replace in the event of damage.



Aluminum Anti-Rack Cam Lock

Commercial quality cast aluminum Cam Lock with stainless steel hasp provides a long lasting, no-rust finish for the life of your trailer. Anti-Rack design (forked Cam with "T" shaped Keeper) forms a structural link between door header and footer reducing door movement, frame torque, and road vibration. Better seal compression to prevent moisture penetration.



Anodized Roof Cove & Bottom Trim

Extruded aluminum Roof Cove (with drip rail) provides extra body support and solid anchoring for roof and prefinished aluminum skin. Special anodizing process assures cove and trim will maintain their original luster for years with minimal maintenance.



Rotary Style Flush Lock

Exclusive flush lock design features an automotive style rotary latching mechanism for extra smooth operation. The progressive pressure latch forms a secure weather-tight door seal. Spring-loaded cover protects locking post automatically when door is open. Opens from the inside even when door is locked.

Options



Fully Customized Interiors



E-Track



Tie-Downs



Double Side Doors



Roll-Up Rear Door



ATP Stone Guard



12V Dome Lights



LED Safety Package



Recessed Step



Tinted Windows



Ramp Door Extension



On-Board Generator

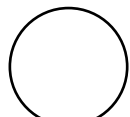

White



Pewter



Black



Beige



Indigo Blue



Dove Gray

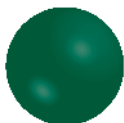

Dark Green



Champagne



Victory Red

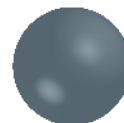

Charcoal Gray



Brandywine

.030 Prefinished Aluminum Skin — 11 Colors

Specifications



CompacVan® Gooseneck

Model Number	Overall				Interior Length		Interior Height		Interior Width	Platform Height	Rear Door		Axle Type	Brake Type**
	L	W (Axle)	W (Body)	H	Lower Deck	Upper Deck	Lower Deck	Upper Deck*			W	H		
14,700# GVWR CVG2025	20'	102"	93 1/4"	8'8"	11'11"	7'11"	6'6"	28"	7'6"	25"	85 3/4"	68 1/2"	4" Drop	Electric
CVG2425	24'	102"	93 1/4"	8'8"	15'11"	7'11"	6'6"	28"	7'6"	25"	85 3/4"	68 1/2"	4" Drop	Electric
CVG2825	28'	102"	93 1/4"	8'8"	19'11"	7'11"	6'6"	28"	7'6"	25"	85 3/4"	68 1/2"	4" Drop	Electric
CVG3225	32'	102"	93 1/4"	8'8"	23'11"	7'11"	6'6"	28"	7'6"	25"	85 3/4"	68 1/2"	4" Drop	Electric
CVG3625	36'	102"	93 1/4"	8'8"	27'11"	7'11"	6'6"	28"	7'6"	25"	85 3/4"	68 1/2"	4" Drop	Electric
CVG4025	40'	102"	93 1/4"	8'8"	31'11"	7'11"	6'6"	28"	7'6"	25"	85 3/4"	68 1/2"	4" Drop	Electric
CVG4425	44'	102"	93 1/4"	8'8"	35'11"	7'11"	6'6"	28"	7'6"	25"	85 3/4"	68 1/2"	4" Drop	Electric
CVG4825	48'	102"	93 1/4"	8'8"	39'11"	7'11"	6'6"	28"	7'6"	25"	85 3/4"	68 1/2"	4" Drop	Electric
20,000# GVWR CVG2027	20'	102"	93 1/4"	8'8"	11'11"	7'11"	6'6"	28"	7'6"	25"	85 3/4"	68 1/2"	4" Drop	Electric
CVG2427	24'	102"	93 1/4"	8'8"	15'11"	7'11"	6'6"	28"	7'6"	25"	85 3/4"	68 1/2"	4" Drop	Electric
CVG2827	28'	102"	93 1/4"	8'8"	19'11"	7'11"	6'6"	28"	7'6"	25"	85 3/4"	68 1/2"	4" Drop	Electric
CVG3227	32'	102"	93 1/4"	8'8"	23'11"	7'11"	6'6"	28"	7'6"	25"	85 3/4"	68 1/2"	4" Drop	Electric
CVG3627	36'	102"	93 1/4"	8'8"	27'11"	7'11"	6'6"	28"	7'6"	25"	85 3/4"	68 1/2"	4" Drop	Electric
CVG4027	40'	102"	93 1/4"	8'8"	31'11"	7'11"	6'6"	28"	7'6"	25"	85 3/4"	68 1/2"	4" Drop	Electric
CVG4427	44'	102"	93 1/4"	8'8"	35'11"	7'11"	6'6"	28"	7'6"	25"	85 3/4"	68 1/2"	4" Drop	Electric
CVG4827	48'	102"	93 1/4"	8'8"	39'11"	7'11"	6'6"	28"	7'6"	25"	85 3/4"	68 1/2"	4" Drop	Electric
22,500# GVWR CVG2039	20'	102"	93 1/4"	8'8"	11'11"	7'11"	6'6"	28"	7'6"	25"	85 3/4"	68 1/2"	4" Drop	Electric
CVG2439	24'	102"	93 1/4"	8'8"	15'11"	7'11"	6'6"	28"	7'6"	25"	85 3/4"	68 1/2"	4" Drop	Electric
CVG2839	28'	102"	93 1/4"	8'8"	19'11"	7'11"	6'6"	28"	7'6"	25"	85 3/4"	68 1/2"	4" Drop	Electric
CVG3239	32'	102"	93 1/4"	8'8"	23'11"	7'11"	6'6"	28"	7'6"	25"	85 3/4"	68 1/2"	4" Drop	Electric
CVG3639	36'	102"	93 1/4"	8'8"	27'11"	7'11"	6'6"	28"	7'6"	25"	85 3/4"	68 1/2"	4" Drop	Electric
CVG4039	40'	102"	93 1/4"	8'8"	31'11"	7'11"	6'6"	28"	7'6"	25"	85 3/4"	68 1/2"	4" Drop	Electric
CVG4439	44'	102"	93 1/4"	8'8"	35'11"	7'11"	6'6"	28"	7'6"	25"	85 3/4"	68 1/2"	4" Drop	Electric
CVG4839	48'	102"	93 1/4"	8'8"	39'11"	7'11"	6'6"	28"	7'6"	25"	85 3/4"	68 1/2"	4" Drop	Electric

How to read Model Number:

CVG 20 2 5



GAWR Classification
of Axles
Overall Length
Model

*If step height is changed due to tow vehicle requirements, the Upper Deck Interior Height will also change accordingly.

**** NEV-R-ADJUST™**
FORWARD SELF-ADJUSTING ELECTRIC BRAKES

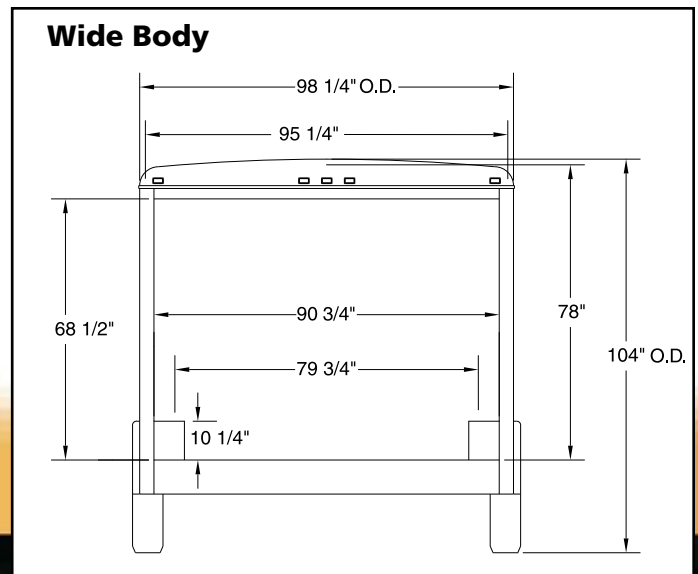
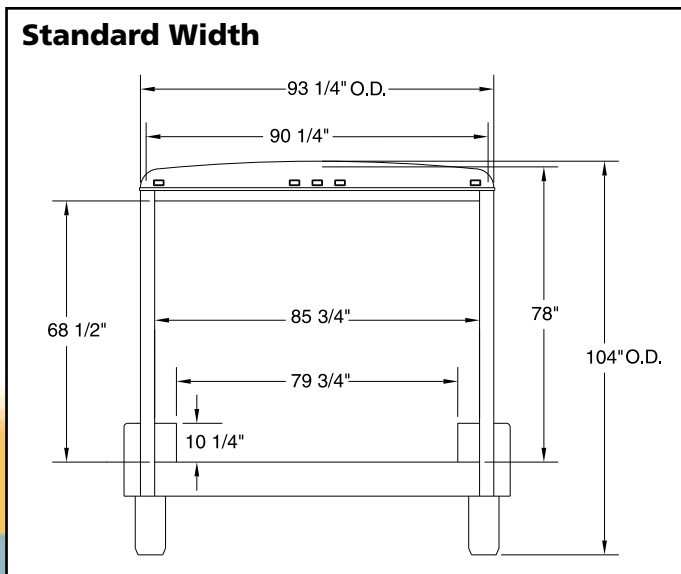



Tire Size	Load Range	Bolt Pattern	Hitch Weight (lbs. at 25%)	Curb Weight (lbs.)	GVWR (lbs.)	GAWR (lbs.)	Average Payload Capacity
16"	D	8-Bolt	910	3640	14,700	12,000	11,060
16"	D	8-Bolt	1030	4120	14,700	12,000	10,580
16"	D	8-Bolt	1153	4610	14,700	12,000	10,090
16"	D	8-Bolt	1275	5100	14,700	12,000	9600
16"	D	8-Bolt	1395	5580	14,700	12,000	9120
16"	D	8-Bolt	1515	6060	14,700	12,000	8640
16"	D	8-Bolt	1635	6540	14,700	12,000	8160
16"	D	8-Bolt	1755	7020	14,700	12,000	7680
17.5"	H	8-Bolt	985	3940	20,000	16,000	16,060
17.5"	H	8-Bolt	1105	4420	20,000	16,000	15,580
17.5"	H	8-Bolt	1228	4910	20,000	16,000	15,090
17.5"	H	8-Bolt	1350	5400	20,000	16,000	14,600
17.5"	H	8-Bolt	1470	5880	20,000	16,000	14,120
17.5"	H	8-Bolt	1590	6360	20,000	16,000	13,640
17.5"	H	8-Bolt	1710	6840	20,000	16,000	13,160
17.5"	H	8-Bolt	1830	7320	20,000	16,000	12,680
16"	D	8-Bolt	1023	4090	22,500	18,000	18,410
16"	D	8-Bolt	1143	4570	22,500	18,000	17,930
16"	D	8-Bolt	1265	5060	22,500	18,000	17,440
16"	D	8-Bolt	1388	5550	22,500	18,000	16,950
16"	D	8-Bolt	1508	6030	22,500	18,000	16,470
16"	D	8-Bolt	1628	6510	22,500	18,000	15,990
16"	D	8-Bolt	1748	6990	22,500	18,000	15,510
16"	D	8-Bolt	1868	7470	22,500	18,000	15,030

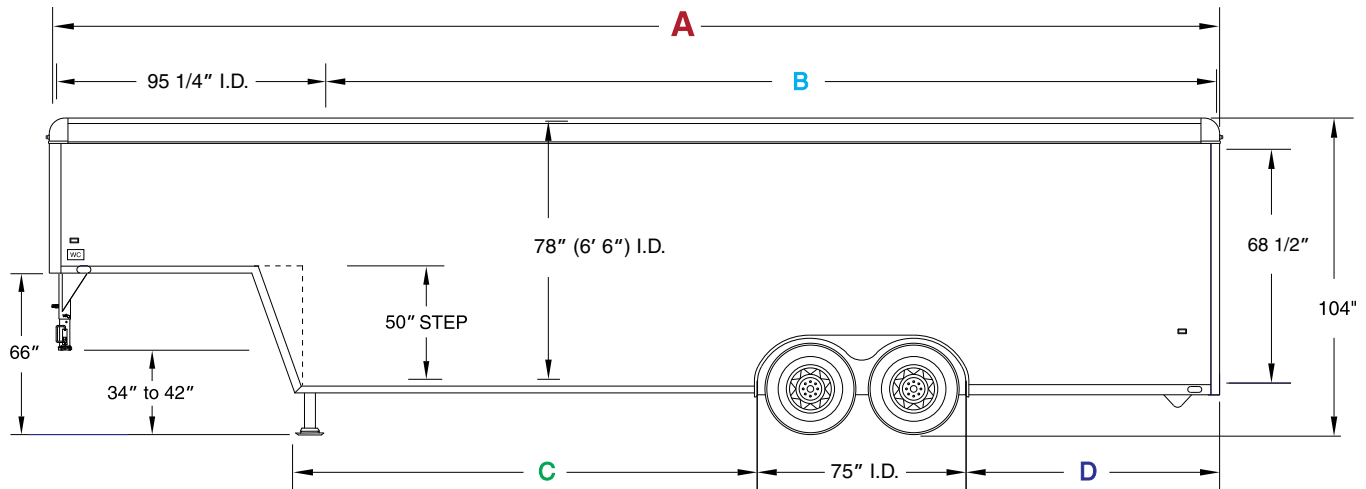
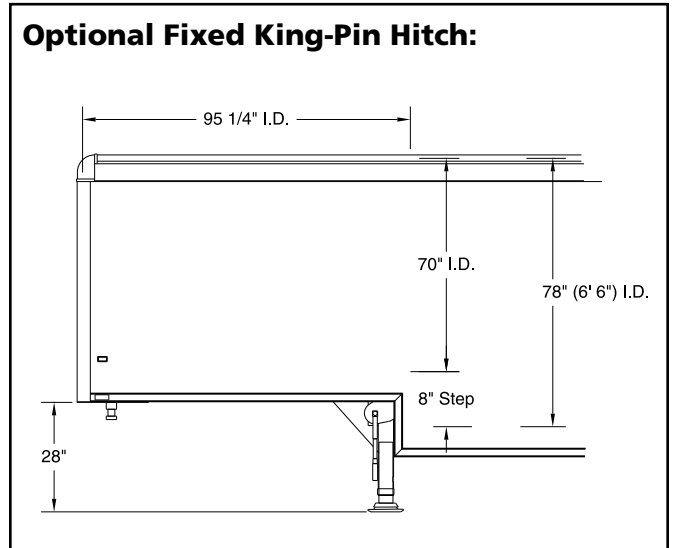

If A = (Overall)	Then B = (Interior)	Then C = (Interior)	Then D = (Interior)
20'	142"	33 1/2"	33 1/2"
24'	190"	67"	48"
28'	238"	101"	62"
32'	286"	134 1/2"	76 1/2"
36'	334"	168"	91"
40'	382"	201 1/2"	105 1/2"
44'	430"	235"	120"
48'	478"	269"	134"

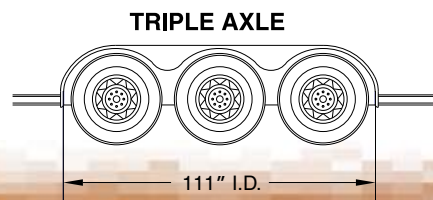

All specifications and features subject to change without notice.

Wells Cargo and Our Legacy of Engineering Leadership



Many people say that all enclosed trailers look pretty much alike. We consider that a compliment since it was Wells Cargo who pioneered the industry over 55 years ago. State-of-the-art takes on a whole new meaning when you compare the first trailer we built in 1954 with our product line today. Old "No. 1" looked pretty good back then, but we've come a long way since. Experience has made the difference and ours is unmatched. Our Research & Development facilities keep us the frontrunners of the industry. After thorough evaluation and comparison, we think you'll agree that Wells Cargo has earned our long standing reputation as the premium cargo trailer on the market and the best overall investment.

Rest assured that after you make the decision to buy a Wells Cargo, our commitment to you is not over. Our comprehensive 6-Year "Never Look Back" Warranty Program is more than just words. It's about how quickly and responsibly we respond to your needs. It's the peace-of-mind you get knowing your investment is protected by an established company with a solid reputation. If our work or materials are at fault, we'll make it right. Any one of our six manufacturing facilities or our national network of professional dealers stand ready to service your trailer should the unlikely need arise.



More Great Trailers

For **WORK**, durable Wells Cargo trailers are used every day by Contractors, Landscapers, Fire Departments, Utility Companies, Heavy and Light Industry; anywhere value of investment is critical.

For **FUN**, you'll see Wells Cargo trailers carrying race cars, collector cars, snowmobiles, motorcycles, ATV's, antiques, and recreational/sporting equipment; anywhere reliable service and carefree towing is a must. You'll see Wells Cargo trailers pulled by big trucks, little trucks, passenger cars, and motorhomes.

You'll find Wells Cargo trailers in almost any situation requiring dependable, economical transportation and storage.



AUTHORIZED WELLS CARGO DEALER



©Wells Cargo, Inc. 2005 LITHO USA Form GOOSENECK 605R709

(800) 348-7553

www.wellscargo.com

**Elkhart, IN
Carbondale, PA**

**Waco, TX
Phoenix, AZ**

**Ogden, UT
Waycross, GA**