

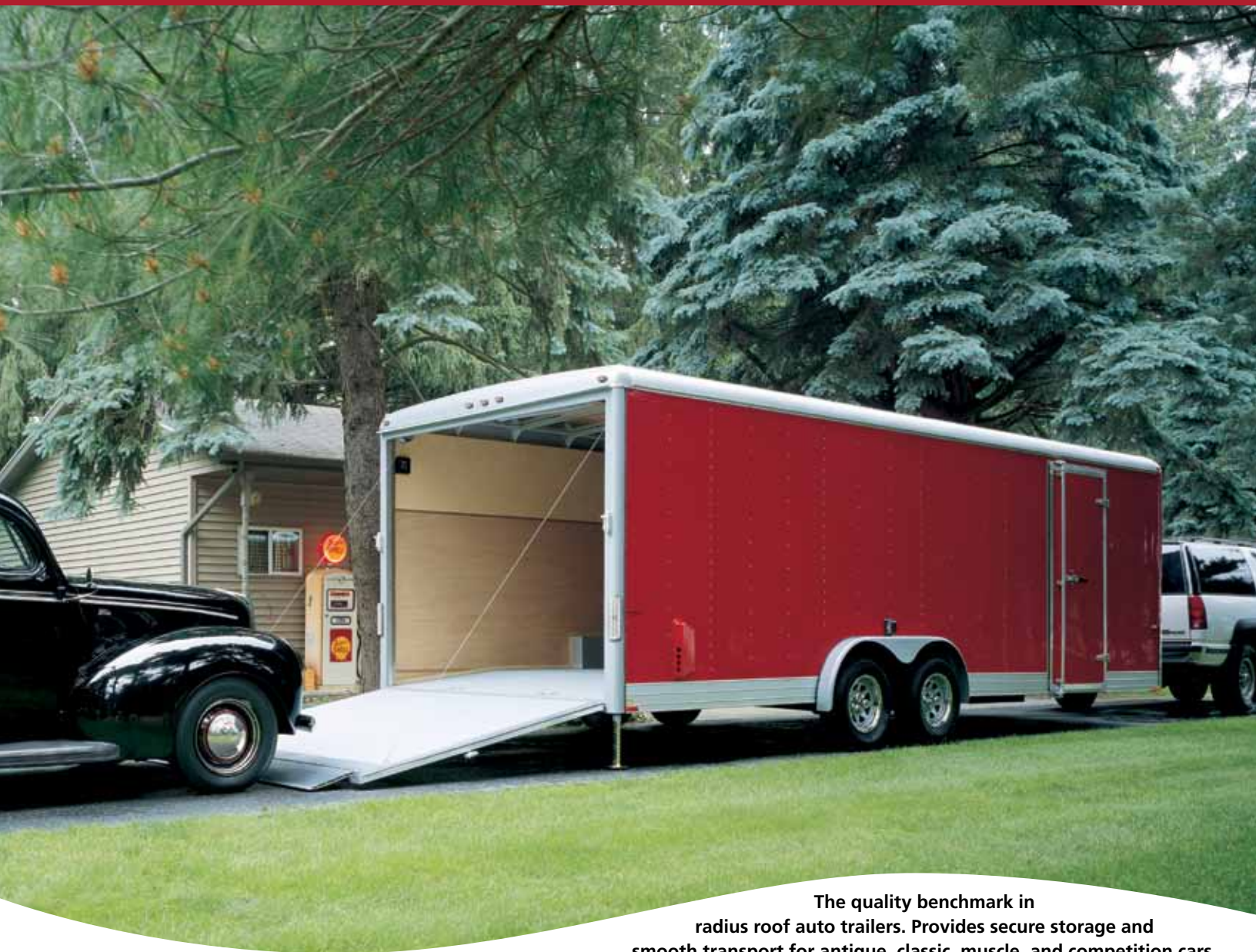

Since 1954

Auto Trailers



The quality benchmark in radius roof auto trailers. Provides secure storage and smooth transport for antique, classic, muscle, and competition cars. Designed, engineered, and manufactured by the most respected name in the cargo trailer industry — Wells Cargo.

*With a Wells Cargo Behind . . . You Never Look Back!*TM

AW



AW Series Includes:

- Torflex® Rubber Torsion Suspension with E-Z Lub Hubs
- E-Coated Silver Spoke Wheels
- Rear Ramp Door with Dual Spring Assist Cables
- Aluminum Anti-Rack Cam Lock with Stainless Steel Hasp
- Rear Cornerpost Stab Jacks
- Reinforced “No Show” Beavertail (4’ long)
- Side Door: 30” to 36” Flush Lock or 48” Bar Lock
- LED Exterior Lighting includes Wells Cargo Exclusive Safety Package
- Dome Lights with Wall Switch
- Extruded Aluminum Roof Cove/Drip Rail with Anodized Finished
- Extruded Aluminum Bottom Trim with Anodized Finished
- Smooth Aluminum Teardrop Fenderettes
- .030 Prefinished Aluminum Exterior Skin (11 colors)
- Corrosion Preventative Compound Undercoating
- Jack Ram Hoist with Sand Pad
- Safety Chains Meet D.O.T. Requirements
- Breakaway System with Wet Cell Battery



Best of Class

The Wells Cargo *autoWagon*® is universally recognized by car collectors and enthusiasts alike as the “Best of Class” among enclosed auto trailers. Our classic radius roof model has earned that reputation with premium materials and superior craftsmanship. While others look to skimp and cut corners, we constantly search for innovative ways to improve performance and enhance durability. No one offers more standard equipment. No one offers more safety features. And, no one offers more value at resale time. With a wide selection of sizes ranging from 18’ to 32’, there’s sure to be an *autoWagon*® model just right for your trailering needs. Tap into our long list of customizing options to create your own “Best of Class”.



Cornerpost Stabilizer Jacks



Rear Ramp Door



Smooth Aluminum Teardrop Fenderettes



Side Door with Bar Lock (Roadside Driver Exit Door)



Model AW2022

(Features optional equipment available at additional charge.)



autoWagon®

| | 7,700 GVWR | 10,000 GVWR |
|-----------------------------|-------------------------------|-------------------------------|
| AXLE TYPE: | 4" Drop | 4" Drop |
| ELECTRIC BRAKE TYPE: | Nev-R-Adjust (self-adjusting) | Nev-R-Adjust (self-adjusting) |
| RADIAL TIRE SIZE: | 15" | 15" |
| LOAD RANGE: | C | D |
| BOLT PATTERN: | 5-Bolt/4.5 | 6-Bolt/5.5 |
| INTERIOR FLOOR: | 3/4" | 3/4" |
| INTERIOR WALL: | 1/4" | 1/4" |
| HITCH BALL SIZE: | 2 5/16" | 2 5/16" |



Specifications and features subject to change without notice.



AWG



AWG Series Includes:

- Rear Ramp Door with Dual Spring Assist Cables
- Aluminum Anti-Rack Cam Lock with Stainless Steel Hasp
- Rear Cornerpost Stab Jacks
- Reinforced "No Show" Beavertail (4' long)
- Side Door: 30" to 36" Flush Lock or 48" Bar Lock
- Tandem 2-Speed Landing Gear
- LED Exterior Lighting includes Wells Cargo Exclusive Safety Package
- Dome Lights with Wall Switch
- Extruded Aluminum Roof Cove/Drip Rail with Anodized Finish
- Extruded Aluminum Bottom Trim with Anodized Finish
- Smooth Aluminum Teardrop Fenderettes
- .030 Prefinished Aluminum Exterior Skin (11 colors)
- Corrosion Preventative Compound Undercoating
- Adjustable Height Ball Coupler Hitch
- Safety Chains Meet D.O.T. Requirements
- Breakaway System with Wet Cell Battery



Front Runner

Welcome to the big time. If large capacity and rugged durability are on your "must have" list, step up to the next level with a Wells Cargo **autoWagon®** **Gooseneck**. The **autoWagon® Gooseneck** is no casual weekender; it's a heavy-duty workhorse for the serious professional. Designed to rack up the miles with maximum performance and minimal maintenance, leading the pack just seems natural. The **autoWagon® Gooseneck** is available in two different styles: the standard gooseneck and the new tapered nose gooseneck which provides excellent maneuverability and maximum turning radius with short bed trucks.



Tandem, 2-Speed Landing Gear



Tapered Gooseneck



Standard AWG Hitch (2 5/16" Adjustable Height Ball Hitch)



Model AWG3625W

(Features optional equipment available at additional charge.)



| | 14,700 GVWR | 22,500 GVWR |
|-----------------------------|--------------------------------------|--------------------------------------|
| # of Axles: | Tandem (2) | Triple (3) |
| Axle Type: | 4" Drop | 4" Drop |
| Electric Brake Type: | Nev-R-Adjust (self-adjusting) | Nev-R-Adjust (self-adjusting) |
| Radial Tire Size: | 16" | 16" |
| Load Range: | D | D |
| Bolt Pattern: | 8-Bolt/6.5 | 8-Bolt/6.5 |
| Interior Floor: | 3/4" | 3/4" |
| Interior Wall: | 3/8" | 3/8" |
| Standard Hitch: | 2 5/16" Adjustable Height Ball Hitch | 2 5/16" Adjustable Height Ball Hitch |



Specifications and features subject to change without notice.



autoWagon® Gooseneck

AS

Versatility To The Max!

The Wells Cargo *autoSport*[®] with its stylish and streamlined V-Front profile is getting high marks from those whose passion includes more than one set of wheels. Clearly it's great for hauling cars; the standard rear ramp door, cornerpost stabilizer jacks, and "no-show" beavertail tell you that. However, by adding the optional front ramp door, you open up a whole new level of versatility with drive-off unloading for motorcycles, snowmobiles, ATV's, sandrails . . . whatever your powersport vehicle of choice may be. The *autoSport*[®] is truly a multi-tasking hauling machine. So, if you're looking for maximum utility, maximum performance, and maximum durability – the *autoSport*[®] is for you!



Anodized Aluminum on Nose

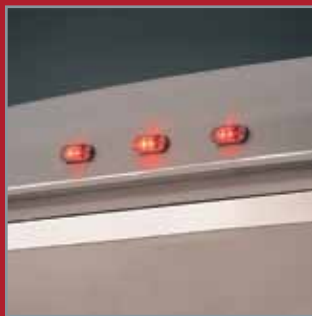

LED Safety Package



ATP Stone Guard on Nose



Aluminum Anti-Rack Cam Lock



AS Series Includes:

- 5 ft. Long V-Front
- ATP Stone Guard and Anodized Aluminum on Nose Section
- Rear Ramp Door with Dual Spring Assist Cables
- Aluminum Anti-Rack Cam Lock with Stainless Steel Hasp
- Rear Cornerpost Stab Jacks
- Reinforced "No Show" Rear Beavertail (4' long)
- Side Door: 30" to 36" Flush Lock or 48" Bar Lock
- LED Exterior Lighting includes Wells Cargo Exclusive Safety Package
- Dome Lights with Wall Switch
- Extruded Aluminum Roof Cove/Drip Rail with Anodized Finish
- Extruded Aluminum Bottom Trim with Anodized Finish
- Smooth Aluminum Teardrop Fenderettes
- .030 Prefinished Aluminum Exterior Skin (11 colors)
- Corrosion Preventative Compound Undercoating
- Jack Ram Hoist with Sand Pad
- Safety Chains Meet D.O.T. Requirements
- Breakaway System with Wet Cell Battery



Model AS2524W

(Features optional equipment available at additional charge.)



autoSport®

| BASIC SPECS | | 7,700 GVWR | 10,000 GVWR |
|------------------|----------------------|-------------------------------|-------------------------------|
| | Axle Type: | 4" Drop | 4" Drop |
| | Electric Brake Type: | Nev-R-Adjust (self-adjusting) | Nev-R-Adjust (self-adjusting) |
| | Radial Tire Size: | 15" | 15" |
| | Load Range: | C | D |
| | Bolt Pattern: | 5-Bolt/4.5 | 6-Bolt/5.5 |
| | Interior Floor: | 3/4" | 3/4" |
| | Interior Wall: | 1/4" | 1/4" |
| Hitch Ball Size: | 2 5/16" | 2 5/16" | |



Specifications and features subject to change without notice.



Quality Construction Quality Control

Solid engineering delivers solid performance.

Even though an auto trailer may be considered a recreational trailer by some, the autoWagon®/ autoSport® both have the same backbone and rugged heritage as our commercial grade trailers. You can tell by our advanced design, top-notch components, and detailed “fit & finish” that we’re serious about our position as the industry leader. This focus on quality means you’ll run out of destinations long before your autoWagon® or autoSport® is ready to call it quits.



LED Stop/Tail/Turn Light



SmartWire™ Technology (12V)



Breakaway System with Wet Cell Battery

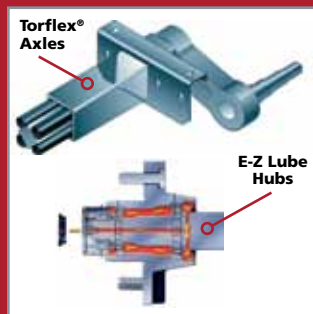

Torflex® Rubber Suspension



SMART TECHNOLOGY™

Wells Cargo has been building enclosed trailers for over 50 years. That kind of experience is hard to find and it makes a real difference. We’ve leveraged that experience and apply it everyday in our manufacturing techniques. We call it “Smart Technology”. You’ll see it throughout our trailers; and better yet, you’ll appreciate it after years of carefree service. Look for our Smart Technology in the following areas:

SmartFrame Technology™: The strongest frame design in the industry and the source of our legendary durability. Tubular steel main rails, radius cornerposts (front & rear), and fully integrated A-Frame are just a few examples. These frame photos (above & right) highlight many others.

SmartWire Technology™: All 12 volt wiring is completely weather protected with no direct exposure to the elements or road hazards. The molded, 4-wire cable is routed inside the tubular main rail. All brake wiring is run through conduit into a welded channel on the axle. Brake wiring is shielded by a plastic loom and the connections are made inside a water resistant cap.

SmartShield Technology™: Every Wells Cargo chassis is protected with a laboratory tested, Corrosion Preventative Compound (CPC), to deter the accumulation of rust. Painted steel surfaces feature a state-of-the-art two-stage process including both an epoxy primer coat and urethane top coat for a smooth, long lasting finish. Also, a special corrosion barrier is applied between the steel frame and aluminum skin to prevent electrolysis.

Door Openings are Framed with Steel Channels & Gusseted

Recessed Wall Posts at Top & Bottom Sill for Smooth Skin Installation

Gussets at Major Stress Points

Galvanized Steel Roof Bows



Diagonal Welded Reinforcements on Rear Sidewall Section

4 ft. Long "No-Show" Beavertail Lowers Platform Height without Sacrificing Chassis Strength

Full Width Hinge with 3/4" Diameter Steel Pin

C-channel Welded Perimeter Ramp Door Frame

Welded Gussets in each Corner of Ramp Door Frame

E-Coated Silver Spoke Wheels

Radius Steel Cornerposts (rear)

Zinc Plated Adjustable Height Rear Cornerpost Stabilizer Jacks

Three (3) Full Length C-channel Reinforcement Supports Prevent Sagging & Bowing

Center Tube of A-Frame Extends 4 ft. into Chassis and Anchored to Tube Crossmember

Tubular Steel Main Rail

Fully Integrated A-Frame Extends into Chassis

3-piece Tubular Steel A-Frame

Positive Lock Ball Coupler Hitch with Replaceable "Locking Dog"

Safety Chains Meet D.O.T. Requirements

Full Height Steel C-channel Crossmembers

Recessed Step (optional) with Welded Steel Framing and Integrated into Chassis

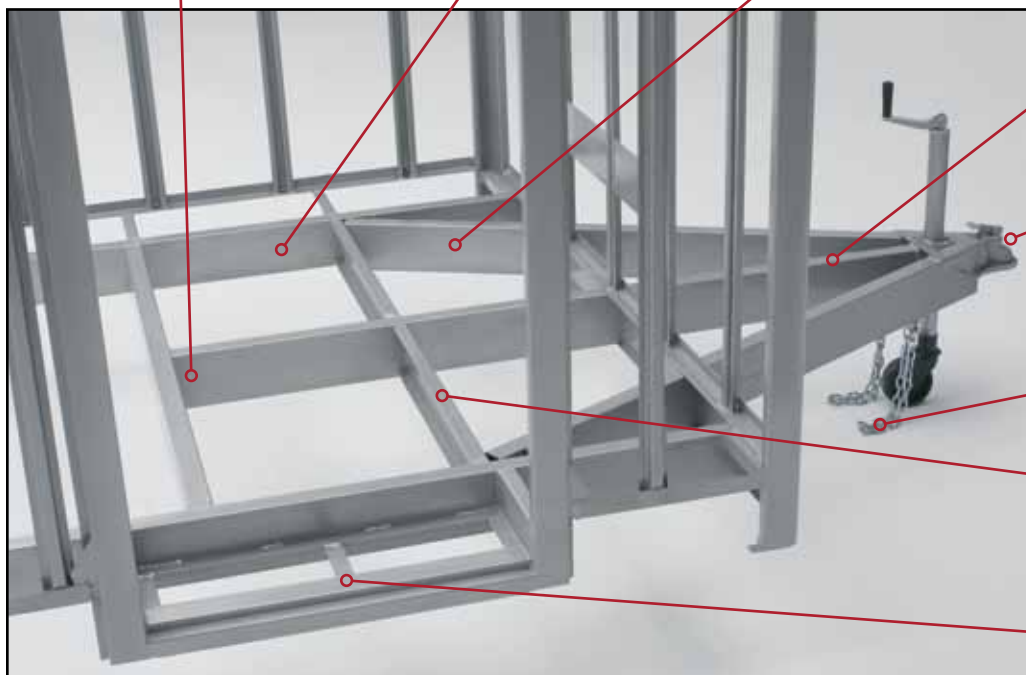

OPT

Options, Upgrades & Customizing

Every Wells Cargo auto trailer is jam-packed with a laundry list of quality standard features. From a practical point of view, that's what you want. However, the real thrill comes from taking that dream trailer concept in your head and turning it into a reality. Wells Cargo has the selection, the resources, and the experience to build your trailer just the way you want it. Is flash your style? Choose from hundreds of striking exterior options. Or, maybe you're more of the hands-on type and want a garage on wheels. We can do that, too. Check out our generous assortment of interior upgrades that will really make you feel at home. It doesn't matter the size or the application, Wells Cargo is up to the challenge.



1



2

1. Recessed Step
2. Triple Axle
3. On-Board Generator
4. Vice Lock Style Door Hasp (Side or Rear Door)
5. Custom Interior: ATP Flooring, Aluminum Side-walls, Overhead Cabinet, Workbench, Sub-Floor Tire Carrier, D-Ring Tie-Downs, and Fluorescent Lighting.



3

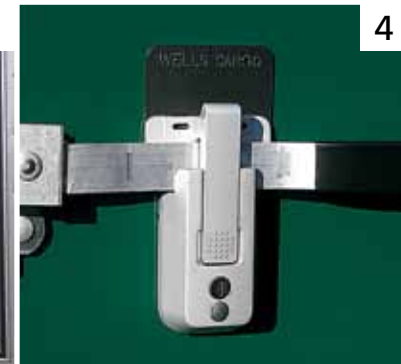

4



5



Roof Vent Cover



Radius Tinted Windows



Halogen Exterior Lights



Access Doors



- 6. Halogen Backup Light
- 7. Extruded Aluminum Ramp Door Extension
- 8. AlumaSport Aluminum Wheels
- 9. Sub-Floor Tire Carrier with Spare Tire
- 10. Roof Top Observation Platform with Safety Railing



- 11. Aerodynamic Nose Cone®, ATP Stone Guard and Power Jack
- 12. Custom Interior: ATP Runners, B/W Checkerboard Vinyl Flooring, D-Ring Tie-Downs, Gray Vinyl Sidewalls, Workbench and Ladder
- 13. Roll-Out Style Awning



SPECIFICATIONS

autoWagon®

| | Body Length | Overall Length | Overall: Width (Axle) | Overall: Width (Body) | Overall: Height | Interior: Length | Interior: Width | Interior: Height | Wheel Box Clearance | Ramp Door: Width | Ramp Door: Height | Platform Height | Axle: Quantity | Axle: Suspension | |
|-------|-------------|----------------|-----------------------|-----------------------|----------------------------------|------------------|-----------------|------------------|---------------------|------------------|----------------------------------|-----------------|----------------|------------------|----------|
| 2 Ton | AW1822 | 18'0" | 22'0" | 102" | 93 ¹ / ₄ " | 8'5" | 17'9" | 7'6" | 6'6" | 81" | 85 ³ / ₄ " | 73" | 17" | 2 | Torflex® |
| | AW2022 | 20'0" | 24'0" | 102" | 93 ¹ / ₄ " | 8'5" | 19'9" | 7'6" | 6'6" | 81" | 85 ³ / ₄ " | 73" | 17" | 2 | Torflex® |
| | AW2222 | 22'0" | 26'0" | 102" | 93 ¹ / ₄ " | 8'5" | 21'9" | 7'6" | 6'6" | 81" | 85 ³ / ₄ " | 73" | 17" | 2 | Torflex® |
| 4 Ton | AW2422 | 24'0" | 28'0" | 102" | 93 ¹ / ₄ " | 8'5" | 23'9" | 7'6" | 6'6" | 81" | 85 ³ / ₄ " | 73" | 17" | 2 | Torflex® |
| | AW1824 | 18'0" | 22'0" | 102" | 93 ¹ / ₄ " | 8'5" | 17'9" | 7'6" | 6'6" | 81" | 85 ³ / ₄ " | 73" | 17" | 2 | Torflex® |
| | AW2024 | 20'0" | 24'0" | 102" | 93 ¹ / ₄ " | 8'5" | 19'9" | 7'6" | 6'6" | 81" | 85 ³ / ₄ " | 73" | 17" | 2 | Torflex® |
| | AW2224 | 22'0" | 26'0" | 102" | 93 ¹ / ₄ " | 8'5" | 21'9" | 7'6" | 6'6" | 81" | 85 ³ / ₄ " | 73" | 17" | 2 | Torflex® |
| | AW2424 | 24'0" | 28'0" | 102" | 93 ¹ / ₄ " | 8'5" | 23'9" | 7'6" | 6'6" | 81" | 85 ³ / ₄ " | 73" | 17" | 2 | Torflex® |
| | AW2624 | 26'0" | 30'0" | 102" | 93 ¹ / ₄ " | 8'5" | 25'9" | 7'6" | 6'6" | 81" | 85 ³ / ₄ " | 73" | 17" | 2 | Torflex® |
| | AW2824 | 28'0" | 32'0" | 102" | 93 ¹ / ₄ " | 8'7" | 27'9" | 7'6" | 6'6" | 81" | 85 ³ / ₄ " | 74" | 18" | 2 | Torflex® |
| | AW3224 | 32'0" | 36'0" | 102" | 93 ¹ / ₄ " | 8'7" | 31'9" | 7'6" | 6'6" | 81" | 85 ³ / ₄ " | 74" | 18" | 2 | Torflex® |

autoWagon® Gooseneck

| | Body Length | Overall Length | Overall: Width (Axle) | Overall: Width (Body) | Overall: Height | Interior: Length (Lower Deck) | Interior: Length (Upper Deck) | Interior: Width | Interior: Height (Lower Deck) | Interior Height (Upper Deck) | Wheel Box Clearance | Ramp Door: Width | Ramp Door: Height | Platform Height | |
|-------|-------------|----------------|-----------------------|-----------------------|----------------------------------|-------------------------------|-------------------------------|-----------------|-------------------------------|------------------------------|---------------------|------------------|----------------------------------|-----------------|-----|
| 5 Ton | AWG2425 | 24'0" | 24'0" | 102" | 93 ¹ / ₄ " | 8'8" | 15'10" | 7'11" | 7'6" | 6'6" | 2'10" | 80" | 85 ³ / ₄ " | 74" | 20" |
| | AWG2825 | 28'0" | 28'0" | 102" | 93 ¹ / ₄ " | 8'8" | 19'10" | 7'11" | 7'6" | 6'6" | 2'10" | 80" | 85 ³ / ₄ " | 74" | 20" |
| | AWG3225 | 32'0" | 32'0" | 102" | 93 ¹ / ₄ " | 8'8" | 23'10" | 7'11" | 7'6" | 6'6" | 2'10" | 80" | 85 ³ / ₄ " | 74" | 20" |
| | AWG3625 | 36'0" | 36'0" | 102" | 93 ¹ / ₄ " | 8'8" | 27'10" | 7'11" | 7'6" | 6'6" | 2'10" | 80" | 85 ³ / ₄ " | 74" | 20" |
| | AWG4025 | 40'0" | 40'0" | 102" | 93 ¹ / ₄ " | 8'8" | 31'10" | 7'11" | 7'6" | 6'6" | 2'10" | 80" | 85 ³ / ₄ " | 74" | 20" |
| 9 Ton | AWG4425 | 44'0" | 44'0" | 102" | 93 ¹ / ₄ " | 8'8" | 35'10" | 7'11" | 7'6" | 6'6" | 2'10" | 80" | 85 ³ / ₄ " | 74" | 20" |
| | AWG4825 | 48'0" | 48'0" | 102" | 93 ¹ / ₄ " | 8'8" | 39'10" | 7'11" | 7'6" | 6'6" | 2'10" | 80" | 85 ³ / ₄ " | 74" | 20" |
| | AWG2439 | 24'0" | 24'0" | 102" | 93 ¹ / ₄ " | 8'8" | 15'10" | 7'11" | 7'6" | 6'6" | 2'10" | 80" | 85 ³ / ₄ " | 74" | 20" |
| | AWG2839 | 28'0" | 28'0" | 102" | 93 ¹ / ₄ " | 8'8" | 19'10" | 7'11" | 7'6" | 6'6" | 2'10" | 80" | 85 ³ / ₄ " | 74" | 20" |
| | AWG3239 | 32'0" | 32'0" | 102" | 93 ¹ / ₄ " | 8'8" | 23'10" | 7'11" | 7'6" | 6'6" | 2'10" | 80" | 85 ³ / ₄ " | 74" | 20" |
| | AWG3639 | 36'0" | 36'0" | 102" | 93 ¹ / ₄ " | 8'8" | 27'10" | 7'11" | 7'6" | 6'6" | 2'10" | 80" | 85 ³ / ₄ " | 74" | 20" |
| | AWG4039 | 40'0" | 40'0" | 102" | 93 ¹ / ₄ " | 8'8" | 31'10" | 7'11" | 7'6" | 6'6" | 2'10" | 80" | 85 ³ / ₄ " | 74" | 20" |
| | AWG4439 | 44'0" | 44'0" | 102" | 93 ¹ / ₄ " | 8'8" | 35'10" | 7'11" | 7'6" | 6'6" | 2'10" | 80" | 85 ³ / ₄ " | 74" | 20" |
| | AWG4839 | 48'0" | 48'0" | 102" | 93 ¹ / ₄ " | 8'8" | 39'10" | 7'11" | 7'6" | 6'6" | 2'10" | 80" | 85 ³ / ₄ " | 74" | 20" |

autoSport®

| | Body Length | Overall Length | Overall: Width (Axle) | Overall: Width (Body) | Overall: Height | Interior: Length | Interior: Length (Excluding V-Front) | Interior: Width | Interior: Height | Wheel Box Clearance | Ramp Door: Width | Ramp Door: Height | Platform Height | Axle: Quantity | |
|-------|-------------|----------------|-----------------------|-----------------------|----------------------------------|------------------|--------------------------------------|-----------------|------------------|---------------------|------------------|----------------------------------|-----------------|----------------|---|
| 2 Ton | AS2322W | 23'0" | 26'1" | 102" | 98 ¹ / ₄ " | 8'5" | 22'9" | 17'9" | 7'11" | 6'6" | 81" | 90 ³ / ₄ " | 73" | 17" | 2 |
| | AS2522W | 25'0" | 28'1" | 102" | 98 ¹ / ₄ " | 8'5" | 24'9" | 19'9" | 7'11" | 6'6" | 81" | 90 ³ / ₄ " | 73" | 17" | 2 |
| | AS2324W | 23'0" | 26'1" | 102" | 98 ¹ / ₄ " | 8'5" | 22'9" | 17'9" | 7'11" | 6'6" | 81" | 90 ³ / ₄ " | 73" | 17" | 2 |
| 4 Ton | AS2524W | 25'0" | 28'1" | 102" | 98 ¹ / ₄ " | 8'5" | 24'9" | 19'9" | 7'11" | 6'6" | 81" | 90 ³ / ₄ " | 73" | 17" | 2 |
| | AS2724W | 27'0" | 30'1" | 102" | 98 ¹ / ₄ " | 8'7" | 26'9" | 21'9" | 7'11" | 6'6" | 81" | 90 ³ / ₄ " | 74" | 18" | 2 |
| | AS2924W | 29'0" | 32'1" | 102" | 98 ¹ / ₄ " | 8'7" | 28'9" | 23'9" | 7'11" | 6'6" | 81" | 90 ³ / ₄ " | 74" | 18" | 2 |
| | AS3124W | 31'0" | 34'1" | 102" | 98 ¹ / ₄ " | 8'7" | 30'9" | 25'9" | 7'11" | 6'6" | 81" | 90 ³ / ₄ " | 74" | 18" | 2 |

Specifications and features subject to change without notice.



| Hitch to Top of Ball | Hitch Ball Size | Hitch Weight | Curb Weight (lb.) | GVWR (lb.) | GAWR (lb.) | Average Payload (lb.) | 12V Trailer End Connector |
|----------------------|----------------------------------|--------------|-------------------|------------|------------|-----------------------|---------------------------|
| 19" | 2 ⁵ / ₁₆ " | 10-15% | 2900 | 7700 | 7000 | 4800 | 7-way |
| 19" | 2 ⁵ / ₁₆ " | 10-15% | 3100 | 7700 | 7000 | 4600 | 7-way |
| 19" | 2 ⁵ / ₁₆ " | 10-15% | 3300 | 7700 | 7000 | 4400 | 7-way |
| 19" | 2 ⁵ / ₁₆ " | 10-15% | 3500 | 7700 | 7000 | 4200 | 7-way |
| 19" | 2 ⁵ / ₁₆ " | 10-15% | 2900 | 10000 | 10000 | 7100 | 7-way |
| 19" | 2 ⁵ / ₁₆ " | 10-15% | 3100 | 10000 | 10000 | 6900 | 7-way |
| 19" | 2 ⁵ / ₁₆ " | 10-15% | 3300 | 10000 | 10000 | 6700 | 7-way |
| 19" | 2 ⁵ / ₁₆ " | 10-15% | 3500 | 10000 | 10000 | 6500 | 7-way |
| 19" | 2 ⁵ / ₁₆ " | 10-15% | 4000 | 10000 | 10000 | 6000 | 7-way |
| 21" | 2 ⁵ / ₁₆ " | 10-15% | 4500 | 10000 | 10000 | 5500 | 7-way |
| 21" | 2 ⁵ / ₁₆ " | 10-15% | 4850 | 10000 | 10000 | 5150 | 7-way |

| Axle: Quantity | Axle: Suspension | Hitch Weight | Curb Weight (lb.) | GVWR (lb.) | GAWR (lb.) | Average Payload (lb.) | 12V Trailer End Connector |
|----------------|------------------|--------------|-------------------|------------|------------|-----------------------|---------------------------|
| 2 | Torflex® | 25% | 4120 | 14700 | 12000 | 10580 | 7-way |
| 2 | Torflex® | 25% | 4610 | 14700 | 12000 | 10090 | 7-way |
| 2 | Torflex® | 25% | 5100 | 14700 | 12000 | 9600 | 7-way |
| 2 | Torflex® | 25% | 5580 | 14700 | 12000 | 9120 | 7-way |
| 2 | Torflex® | 25% | 6060 | 14700 | 12000 | 8640 | 7-way |
| 2 | Torflex® | 25% | 6540 | 14700 | 12000 | 8160 | 7-way |
| 2 | Torflex® | 25% | 7020 | 14700 | 12000 | 7680 | 7-way |
| 3 | Torflex® | 25% | 4506 | 22500 | 18000 | 17994 | 7-way |
| 3 | Torflex® | 25% | 4996 | 22500 | 18000 | 17504 | 7-way |
| 3 | Torflex® | 25% | 5486 | 22500 | 18000 | 17014 | 7-way |
| 3 | Torflex® | 25% | 5966 | 22500 | 18000 | 16534 | 7-way |
| 3 | Torflex® | 25% | 6446 | 22500 | 18000 | 16054 | 7-way |
| 3 | Torflex® | 25% | 6926 | 22500 | 18000 | 15574 | 7-way |
| 3 | Torflex® | 25% | 7406 | 22500 | 18000 | 15094 | 7-way |

| Axle: Suspension | Hitch to Top of Ball | Hitch Ball Size | Hitch Weight | Curb Weight (lb.) | GVWR (lb.) | GAWR (lb.) | Average Payload (lb.) | 12V Trailer End Connector |
|------------------|----------------------|----------------------------------|--------------|-------------------|------------|------------|-----------------------|---------------------------|
| Torflex® | 19" | 2 ⁵ / ₁₆ " | 10-15% | 4160 | 7700 | 7000 | 3540 | 7-way |
| Torflex® | 19" | 2 ⁵ / ₁₆ " | 10-15% | 4240 | 7700 | 7000 | 3460 | 7-way |
| Torflex® | 19" | 2 ⁵ / ₁₆ " | 10-15% | 4360 | 10000 | 10000 | 5640 | 7-way |
| Torflex® | 19" | 2 ⁵ / ₁₆ " | 10-15% | 4440 | 10000 | 10000 | 5560 | 7-way |
| Torflex® | 21" | 2 ⁵ / ₁₆ " | 10-15% | 4750 | 10000 | 10000 | 5250 | 7-way |
| Torflex® | 21" | 2 ⁵ / ₁₆ " | 10-15% | 5080 | 10000 | 10000 | 4920 | 7-way |
| Torflex® | 21" | 2 ⁵ / ₁₆ " | 10-15% | 5440 | 10000 | 10000 | 4560 | 7-way |

.030 Prefinished Aluminum Skin



White



Victory Red



Black



Pewter



Indigo Blue



Champagne



Brandywine



Beige



Charcoal Gray



Dove Gray



Dark Green

Skin colors shown are representative only. See your dealer for accurate samples.

DIMENSIONS

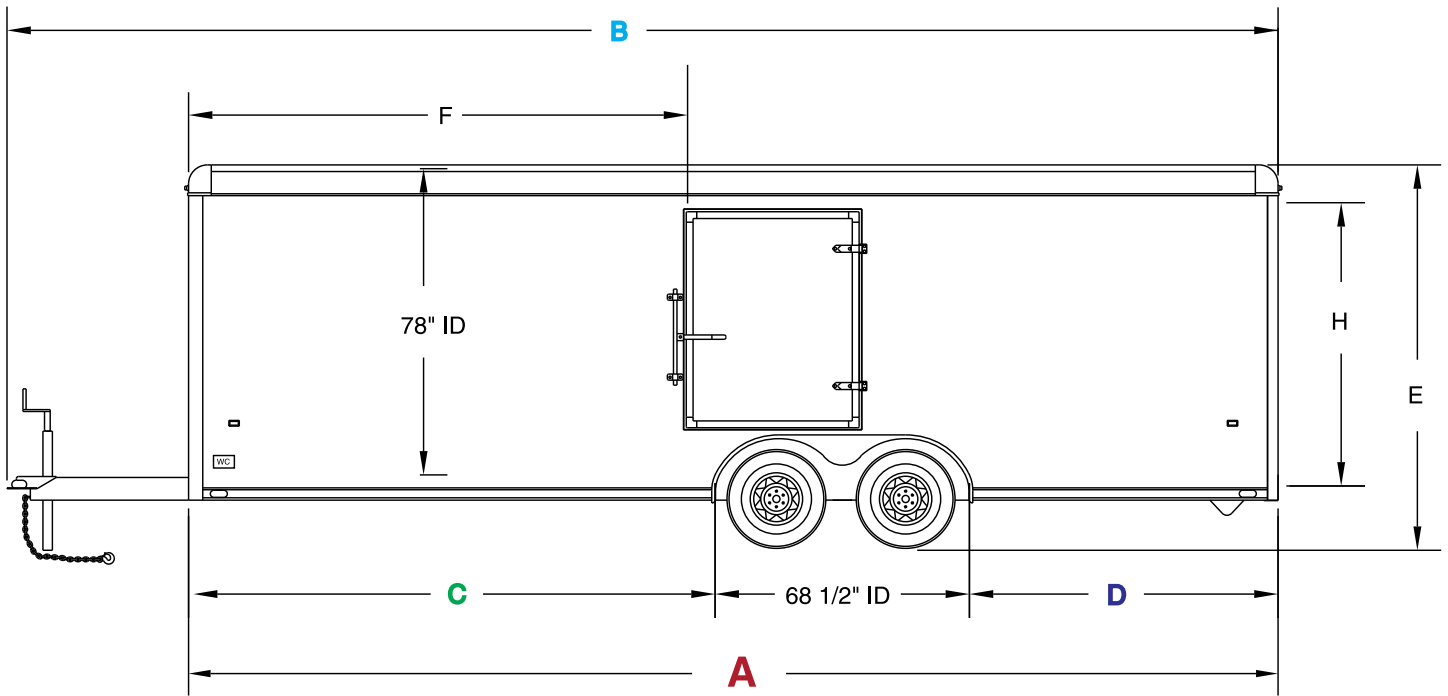

TRIPLE AXLE

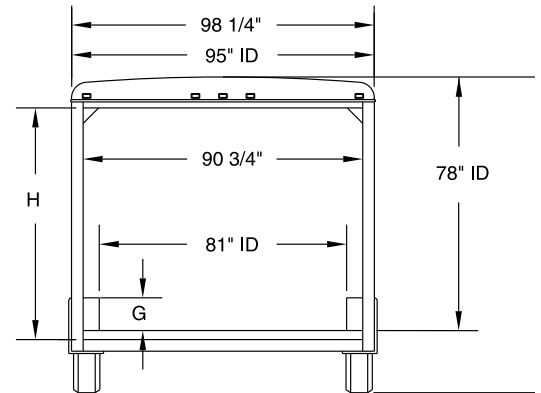
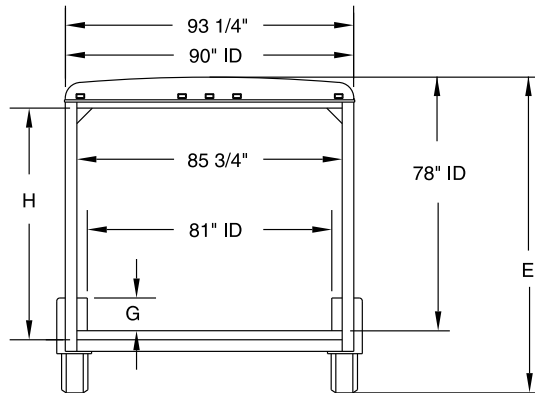
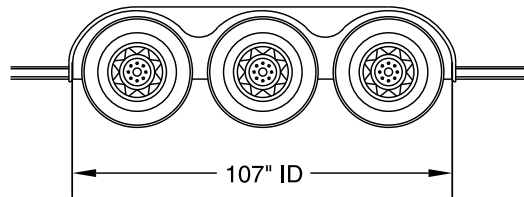

WIDE BODY

| If A = (Body) | Then B = (Overall) | Then C = (I.D.) | Then D = (I.D.) | Then E = (Overall) | Then F = (Common Location) | Then G = (Wheel Box Height) | Then H = (Opening) |
|-------------------------|------------------------------|---------------------------|---------------------------|------------------------------|--------------------------------------|---------------------------------------|------------------------------|
| 18' | 22' | 94" | 50 1/2" | 8'5" | 8'0" | 10" | 73" |
| 20' | 24' | 108 1/2" | 60" | 8'5" | 10'0" | 10" | 73" |
| 22' | 26' | 123" | 69 1/2" | 8'5" | 10'6" | 10" | 73" |
| 24' | 28' | 137" | 79 1/2" | 8'5" | 11'0" | 10" | 73" |
| 26' | 30' | 151 1/2" | 89" | 8'5" | 11'6" | 10" | 73" |
| 28' | 32' | 166" | 98 1/2" | 8'7" | 12'0" | 9" | 74" |
| 32' | 36' | 195" | 117 1/2" | 8'7" | 14'0" | 9" | 74" |

Specifications and features subject to change without notice.

Ball Hitch Models

DIMENSIONS

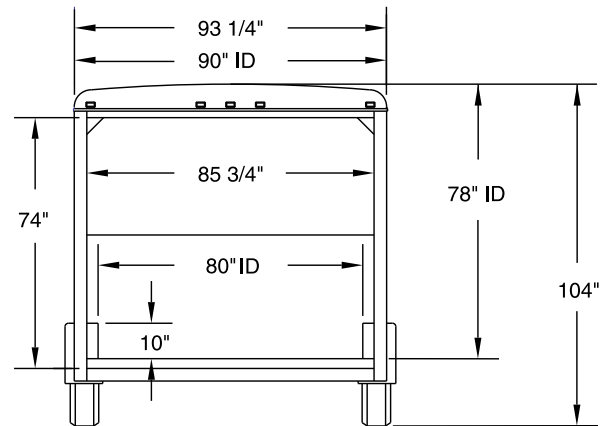
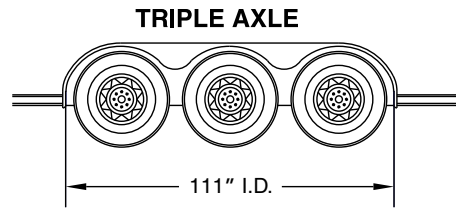
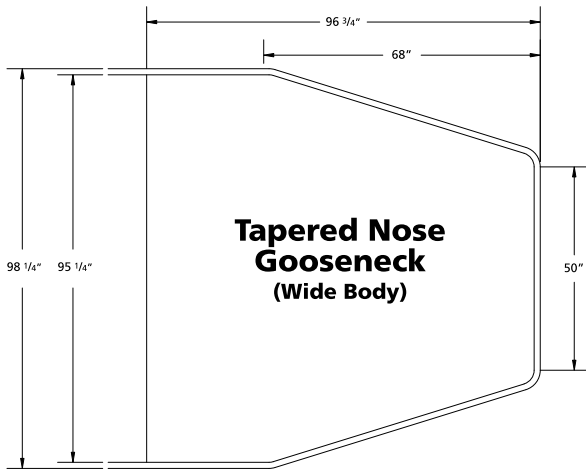
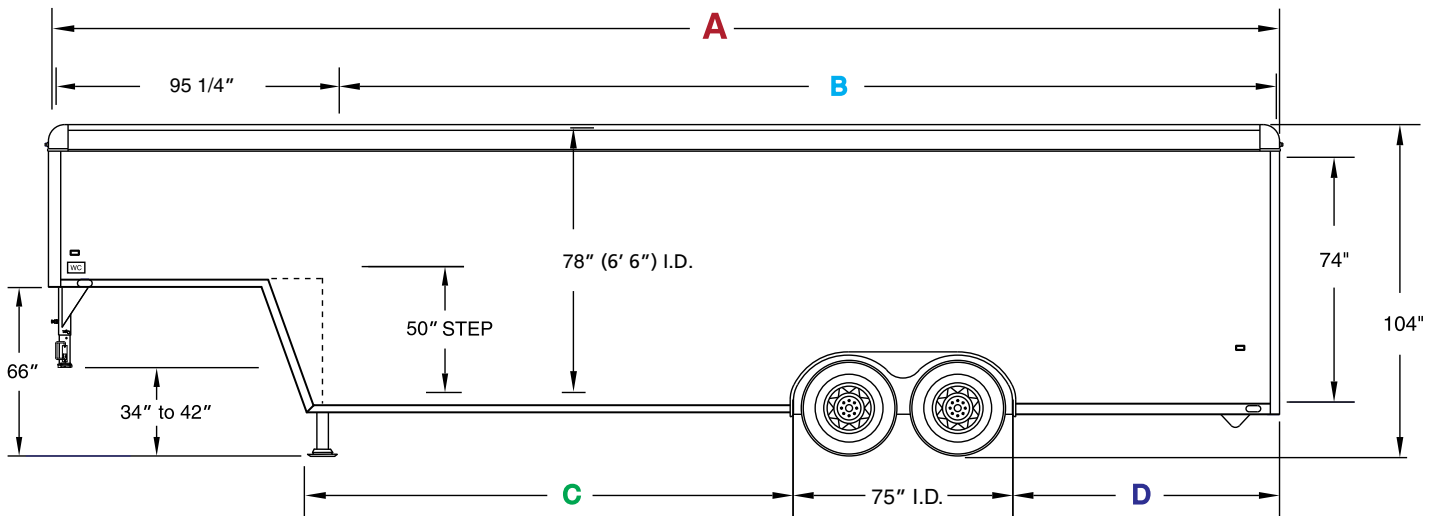

NOTE: The Tapered Nose Gooseneck is also available in the standard 93 1/4" body width.



| If A = (Body) | Then B = (Overall) | Then C = (I.D.) | Then D = (I.D.) |
|-------------------------|------------------------------|---------------------------|---------------------------|
| 24' | 190" | 67" | 48" |
| 28' | 238" | 101" | 62" |
| 32' | 286" | 134 1/2" | 76 1/2" |
| 36' | 334" | 168" | 91" |
| 40' | 382" | 201 1/2" | 105 1/2" |
| 44' | 430" | 235" | 120" |
| 48' | 478" | 269" | 134" |

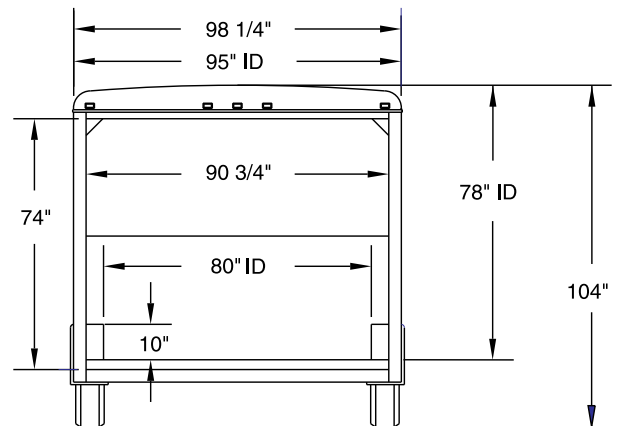

WIDE BODY

Specifications and features subject to change without notice.

Wells Cargo and Our Legacy of Engineering Leadership



Many people say that all enclosed trailers look pretty much alike. We consider that a compliment since it was Wells Cargo who pioneered the industry over 55 years ago. State-of-the-art takes on a whole new meaning when you compare the first trailer we built in 1954 with our product line today. Old "No. 1" looked pretty good back then, but we've come a long way since. Experience has made the difference and ours is unmatched. Our Research & Development facilities keep us the frontrunners of the industry. After thorough evaluation and comparison, we think you'll agree that Wells Cargo has earned our long standing reputation as the premium cargo trailer on the market and the best overall investment.

Rest assured that after you make the decision to buy a Wells Cargo, our commitment to you is not over. Our comprehensive 6-Year "Never Look Back" Warranty Program is more than just words. It's about how quickly and responsibly we respond to your needs. It's the peace-of-mind you get knowing your investment is protected by an established company with a solid reputation. If our work or materials are at fault, we'll make it right. Any one of our six manufacturing facilities or our national network of professional dealers stand ready to service your trailer should the unlikely need arise.



 BY UNIVERSAL TRAILER

More Great Trailers

For **WORK**, durable Wells Cargo trailers are used every day by Contractors, Landscapers, Fire Departments, Utility Companies, Heavy and Light Industry; anywhere value of investment is critical.

For **FUN**, you'll see Wells Cargo trailers carrying race cars, collector cars, snowmobiles, motorcycles, ATV's, antiques, and recreational/sporting equipment; anywhere reliable service and carefree towing is a must. You'll see Wells Cargo trailers pulled by big trucks, little trucks, passenger cars, and motorhomes.

You'll find Wells Cargo trailers in almost any situation requiring dependable, economical transportation and storage.



AUTHORIZED WELLS CARGO DEALER



©Wells Cargo, Inc. 2005 LITHO USA Form AW105R1209

(800) 348-7553

www.wellscargo.com

**Elkhart, IN
Carbondale, PA**

**Waco, TX
Phoenix, AZ**

**Ogden, UT
Waycross, GA**